

## Quality of Reed Relay

SANYU relays conform to the most stringent quality standard required by ATE, medical, military, telecommunication, and other highly demanding customers. Various inspection systems are provided in order to realize highly reliable characteristics and to secure products with the highest standards of quality.

## Basic Flowchart of Relay Inspection Procedure

Process Flow	No.	Inspection Item	Deliver Inspection Criteria		
			Inspection Level	Acceptable Quality Level	
	1	Temperature Cycle	100%		
	2	Drainage Time	100%		
	3	A.D.T.	100%		
	4	No-Load Aging	100%		
	5	Load Aging	100%		
		Appearance/Mark	100%		
		Dimensions	1	0.40%	
		Operating Voltage/Current	100%		
		Release Voltage/Current	100%		
		Contact Resistance	100%		
		Coil Resistance	100%	0.50%	
		Operating/Release Time	100%		
		Dielectric Strength	100%		
		Insulation	Less than $10^{14} \Omega$	1	0.40%
		Resistance	$10^{14} \Omega$ or more	100%	
	6	Chattering	100%		
	7	Thermoelectromotive Force	100%		
		Electrostatic Capacity	100%		
		Transfer Time	n = 5	AC=0	
		DCR, SCR	100%		

The Acceptable Quality Level (AQL) conforms to MIL-STD-105E, counting inspection, and the sample table.

### Contact resistance inspection

Contact resistance is measured to make judgements about contact surface conditions, reed switch sealing, and normal contact items according to the following provisions.

### Contact resistance at the operating voltage

Contact resistance is measured using the four-terminal method, which involves sending a constant current across the contacts and applying the operation voltage to the coils. The measurement criteria are 90% of the maximum values specified by the specifications.

### Process of contact resistance measurement

The measurement of contact resistance values is controlled by operating each sample fivetimes per second and setting the upper limit and lower limit values to within 2 mΩ during the constant resistance measurement. The measuring load is to be 400μV, 1.0mA (1KHz).

### Operating/Release voltage inspection

Measure the operating/release voltage under the measuring conditions specified in the following Fig. 1.

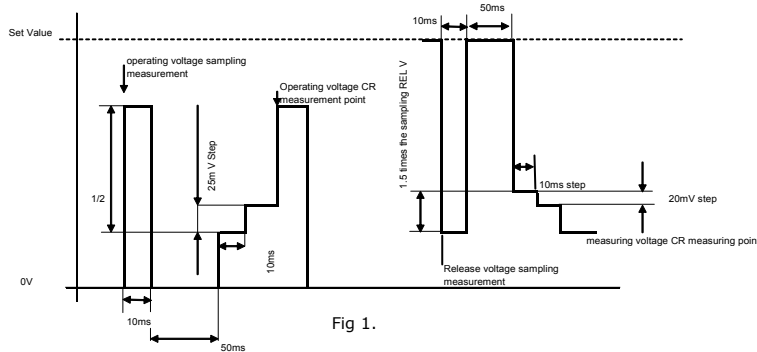

Fig 1.

1. Measure the operating voltage times per second. (See Fig. 1.) Measure the voltage the instant the contacts touch. Boost the voltage in 25mV increments at 10ms intervals for each measurement.

2. Measure the release voltage five per second. (See Fig. 1.) Measure the voltage the instant the contacts separate. Lower the voltage in 25mV increments at 10ms intervals for each measurement.

Measure the operating/release time according to the following provisions.

#### <Reed Relay>

Apply the normal voltage to a tested relay to operate it at 100 Hz (duty 1 : 1). Judge the tested relay according to whether it conforms to 90% max. of the value specified in the specifications. Judge the operating time using the value that includes chattering.

#### <Wet Reed Relay>

Apply the normal voltage to a tested relay. Judge the tested relay according to whether it conforms to maximum value (90% max. of the value specified in the specifications) while changing the frequency over a range from 10 Hz to 100 Hz (due 1 : 1) in one-second intervals. No bouncing is allowable.

Perform the operating/release time inspection using a measuring circuit such as that illustrated below in Fig. 2.

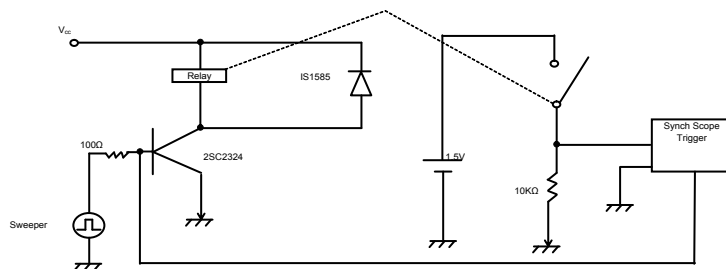

Time chart diagram

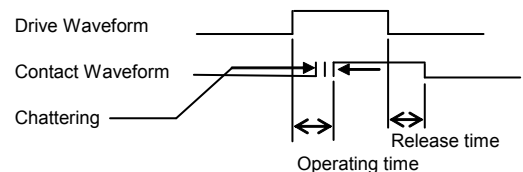

Fig 2.

### Insulation resistance inspection

High insulation resistance is required controlling signals at a microscopic level. In order to satisfy this requirement, this insulation resistance inspection is performed in order to electrically check the sealed condition of the charged resin and cleanness of the materials in the manufacturing processes.

Use a high resistance meter, and measure the insulation resistance two minutes after the specified voltage has been applied. The inspection criterion is 200% of the values specified in the specifications.

### A.D.T. (arc duration time) inspection

Since the internal pressure of contacts in wet reed switches is very high, the contact sealing check and the normal internal pressure became important.

This arc duration time test is performed to check the internal pressure of the switches. To perform this measurement, open and close the switch at the contacts to which a high voltage (120 V, 240 mA) is applied. Then, compare the release waveform (arc waveform) time duration with the specified value to check if the internal pressure is free anomalies caused by gas leaks, glass cracks or other imperfections. The measuring circuit is illustrated below in Fig. 3.

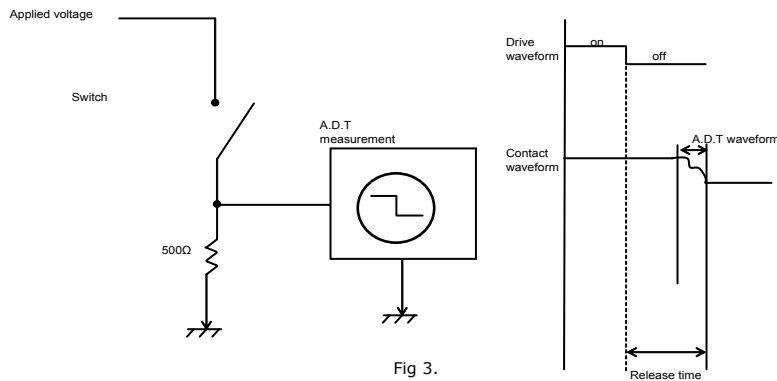

Fig 3.

### Dynamic noises

After the contacts have been closed, the energy is dissipated due to damping oscillations, like the strings of a harp when stretched after they had been released. Part of the contact segments are subjected to stress during the damping oscillation, and the contact segments in the magnetic field of the stressed coils generate a magnetostrictive voltage signal. The voltage is an AC audible signal having a very wide frequency range, and it oscillates as a damping sine wave.

Each inspection standard differs individually. By specifying either peak voltage or the time required until the waveform ends, there are two ways to guarantee the results.

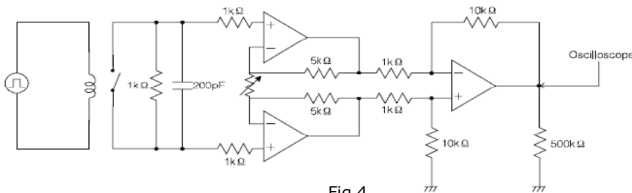

Fig 4.

The measuring circuit is illustrated in Fig. 4.

### Electrostatic capacity inspection

Measure the electrostatic capacity using an impedance analyzer with 1 MHz and DC bias 1 V as the measuring conditions. The standard values should be as specified by the individual specifications.

## High-frequency properties

### 1) Line impedance measuring method

#### a) Measuring circuit

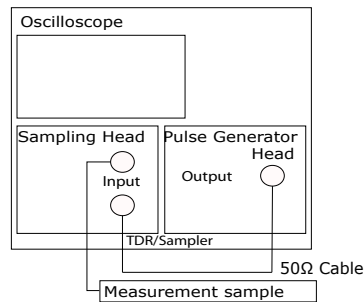

#### b) Measuring method

- (1) Connect the pulse generator output to the lower input terminal of the sampling head input by using a 50Ω cable.
- (2) Connect the upper input terminal of the sampling head to the common input side of the measurement sample, and observe the waveforms by TDR after closing all switches of the route to be measured.
- (3) Repeat step (2).

### 2) Insertion loss measuring method

#### a) Measuring circuit

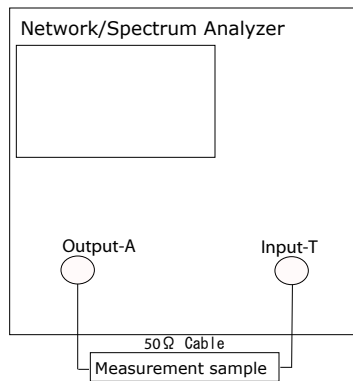

#### b) Measuring method

- (1) Connect the measurement sample to Output A and Input T using two 50Ω cables as illustrated above.
- (2) Eliminate the Cable loss by connecting the output cable and input cable to each other.
- (3) Connect the measuring instrument output cable to the common connector of the measurement sample, and connect the measuring instrument input cable to the connector to be measured.
- (4) Close all switches in the route to be measured, and measure the insertion loss using the spectrum analyzer.
- (5) Repeat steps (3) and (4).

3) Skew measuring method and delay time measuring method  
 a) Measuring circuit

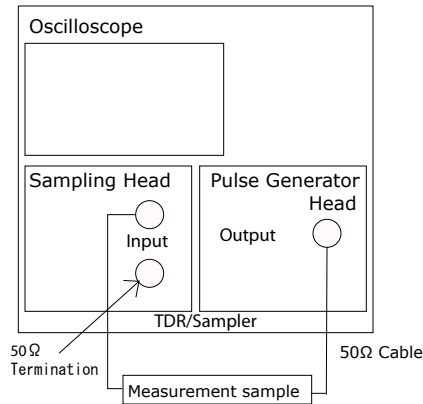

b) Measuring method

- (1) Connect a 50Ω terminator to the lower input terminal of the sampling head.
- (2) Connect a 50Ω cable to the pulse generator output and connect it to the common input side connector of the measurement sample.
- (3) Measure the skew and delay time using TDR after connecting a 50Ω cable to the sampling head and to the connector to be measured.
- (4) Repeat step (3).

4) Isolation measuring method  
 a) Measuring circuit

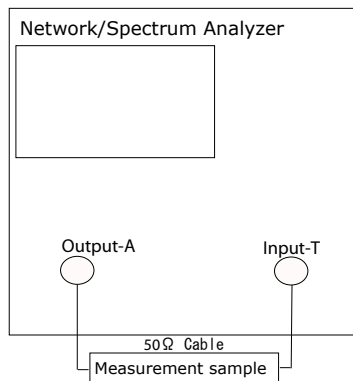

b) Measuring method

- (1) Connect a 50Ω cable to output A and another 50Ω cable to input T.
- (2) Connect the output A cable to the common input side connector of the measurement sample. Then, connect the input T cable to the connector to be measured.
- (3) Eliminate the cable loss by connecting the output cable and input cable to each other.
- (4) Open the switch to be measured. (Terminate other terminals at 50Ω. Close one contact.)
- (5) Measure the isolation using the spectrum analyzer.
- (6) Repeat steps (3) through (5).

## 5) Return loss measuring method

### a) Measuring circuit

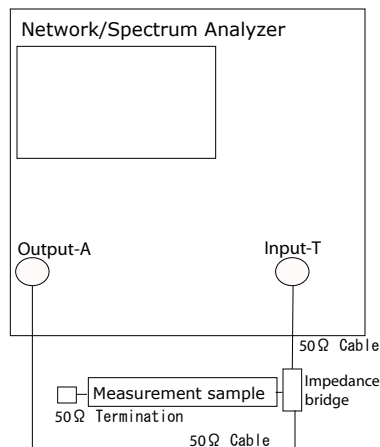

### b) Measuring method

- (1) Connect an impedance bridge across output A and input T.
- (2) Cancel out the signal from output A at the impedance bridge.
- (3) Connect the common input side connector of the measurement sample to the impedance bridge.
- (4) Connect the 50Ω terminator to the connector to be measured.
- (5) Close all switches along the route to be measured.
- (6) Measure the return loss using the spectrum analyzer.
- (7) Repeat steps (4) through (6).

## 6) Line DC resistance measuring method

### a) Measuring circuit

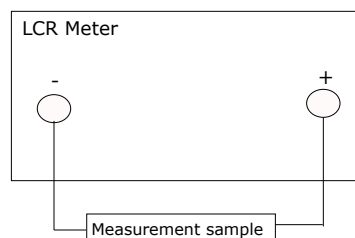

### b) Measuring method

- (1) Connect a cable to the (+) and (-) terminals of the LCR meter, respectively. Measure the resistance value.
- (2) Connect the (+) side cable to the common input side connector.
- (3) Connect the (-) side cable to the connector to be measured and measure the line DC resistance.
- (4) Repeat step (3).